

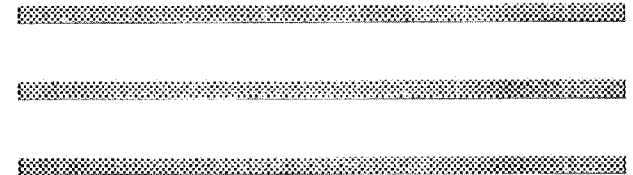

HD 7125/HD 7225

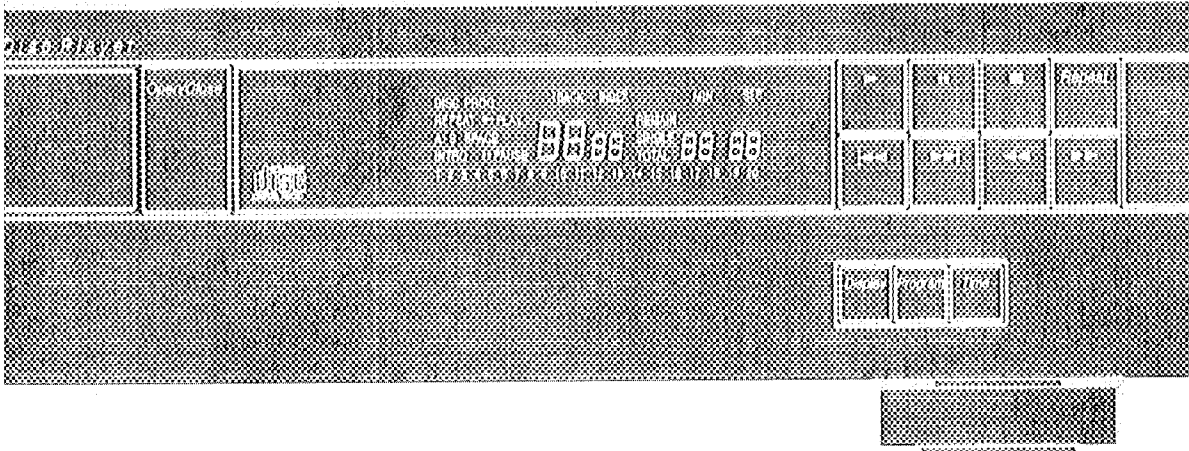

■ **harman/kardon**

Compact Disc Player

INSTALLATION AND OPERATION MANUAL

HD7125/HD7225 BASICS



CAUTION
RISK OF ELECTRIC SHOCK
DO NOT OPEN



CAUTION: TO REDUCE THE RISK OF ELECTRIC SHOCK, DO NOT REMOVE COVER (OR BACK). NO USER-SERVICEABLE PARTS INSIDE. REFER SERVICING TO QUALIFIED SERVICE PERSONNEL.



The lightning flash with arrowhead symbol, within an equilateral triangle, is intended to alert the user to the presence of uninsulated "dangerous voltage" within the product's enclosure that may be of sufficient magnitude to constitute a risk of electric shock to persons.



The exclamation point within an equilateral triangle is intended to alert the user to the presence of important operating and maintenance (servicing) instructions in the literature accompanying the appliance.

WARNING: TO REDUCE THE RISK OF FIRE OR ELECTRIC SHOCK, DO NOT EXPOSE THIS APPLIANCE TO RAIN OR MOISTURE.

**CLASS 1
LASER PRODUCT**

Product complies with DHHS rules CFR subchapter J part 1040:10 at date of manufacture.

DANGER - invisible laser radiation when opened and interlock failed or defeated. Avoid direct exposure to the beam.

CAUTION - use of all controls, adjustments or performance of procedures other than those specified herein may result in hazardous radiation exposure.

CAUTION: TO PREVENT ELECTRIC SHOCK, DO NOT USE THIS (POLARIZED) PLUG WITH AN EXTENSION CORD, RECEPTACLE, OR OTHER OUTLET UNLESS THE BLADES CAN BE FULLY INSERTED TO PREVENT BLADE EXPOSURE.

ATTENTION: POUR PREVENIR LES CHOCS ELECTRIQUES NE PAS UTILISER CETTE FICHE POLARISEE AVEC UN PROLONGATEUR, UNE PRISE DE COURANT OU UNE AUTRE SORTIE DE COURANT, SAUF SI LES LAMES PEUVENT ETRE INSEREES A FOND SANS EN LAISSER AUCUNE PARTIE A DECOUVERT.

This digital apparatus does not exceed the Class B limits for radio noise emissions from digital apparatus as set out in the Radio Interference Regulations of the Canadian Department of Communications. Le présent appareil numérique n'émet pas de Bruits Radioélectriques Dépassant les limites applicables aux appareils numériques de Classe B prescrites dans le règlement sur le brouillage radioélectrique édicté par le ministère des Communications du Canada.





TABLE OF CONTENTS

HD7125/HD7225 Basics	1
Front Panel Controls	4
HD7225 Remote Control	6
Connections	7
Player Operation.....	9
Troubleshooting	12
Specifications	13
Warranty Information	14

Packing Material

Your box and packing material are custom designed to provide optimum protection for your compact disc player. Be sure to save the box and packing material in case you need to transport or ship the unit at some future time (e.g., service or moving).

Warranty card (USA only)

Fill out the warranty card and save your sales receipt. Your sales receipt is your proof of purchase and you may need it to establish the data on which your warranty begins. You will be required to show it for service during the duration of your Limited Warranty.

Thank you for choosing a Harman Kardon compact disc player. This is a superb piece of high fidelity equipment that has been meticulously designed to provide you with thousands of hours of enjoyment.

Both the HD7125 and HD7225 compact disc players use Harman Kardon's 3D Bit Stream technology for conversion of the digital signal to analog, which results in improved imaging and a smoother, more natural sound from your compact discs.

To appreciate the full performance of this sophisticated unit, please be sure to read this owner's manual and use your CD player only in accordance with its instructions. Keep the manual in a safe place for future reference.





Placement

The HD7125/HD7225 is fully shielded and may be placed on top of or under other stereo components as long as the "feet" provide sufficient clearance for cooling of the component below. Please make sure that the HD7125/HD7225 receives adequate ventilation. It should always be located away from heat sources such as radiators, fireplaces, stoves, and other appliances that produce heat. Avoid placing the unit in locations that receive prolonged direct sunlight or extremely low temperatures. While your compact disc player is designed to be vibration-resistant, excessive shocks or placement too close to large speakers can cause "stuttering" or skipping. When choosing a place for your new CD player, take the same precautions you would with a turntable.

Care of the laser pickup

The laser pickup that detects the music recorded on a CD is located under the compact disc drawer. The laser pickup, especially its precision lens, is particularly sensitive to dust. Keep the disc drawer closed when the unit is not in use, and do not put your hand inside the unit.

Interference

This compact disc player uses high-frequency signals that can sometimes interfere with reception in tuners and television. If you start to experience reception problems after connecting and turning on your CD player, move the CD player farther away from your tuner or television set or turn the CD player off when not in use.

Power source

The HD7125/HD7225 should be connected only to a 120 volt, 60 cycle power supply.

Power cord protection

The power cord should be routed in such a way that it is not likely to be walked on or pinched by items laying on or against it. Any power cord is susceptible to stress at the point where it joins the unit, so take care not to fold or bend it excessively at those points. Never pull or stretch the cord. The CD player's power cord should be unplugged from the outlet when the unit is left unused for a long period of time.

Cleaning

Use only a clean dry cloth to clean your compact disc player. Do not use solvents such as alcohol, benzine, gasoline, etc. Take care that excessive dust does not accumulate on your unit, and that objects are not dropped inside or liquids spilled into the unit.

Water and moisture

Do not operate this compact disc player around water (e.g., near a swimming pool, sink, or in a wet basement).

Abnormal smells

If you detect an abnormal smell or smoke, immediately turn the compact disc player off and pull out the power cord. Contact your dealer or nearest Harman Kardon service center.

Service

Your compact disc player should be serviced by authorized Harman Kardon service personnel when

- The plug or power cord has been damaged.
- Objects have fallen into the unit.
- Liquid has been spilled into the unit.
- The unit has been exposed to rain.
- The unit does not operate normally.
- The unit has been dropped or the cabinet has been damaged.

Please do not attempt to service your compact disc player beyond the troubleshooting suggestions in this manual. All other service should be referred to authorized Harman Kardon service personnel.



FRONT PANEL CONTROLS

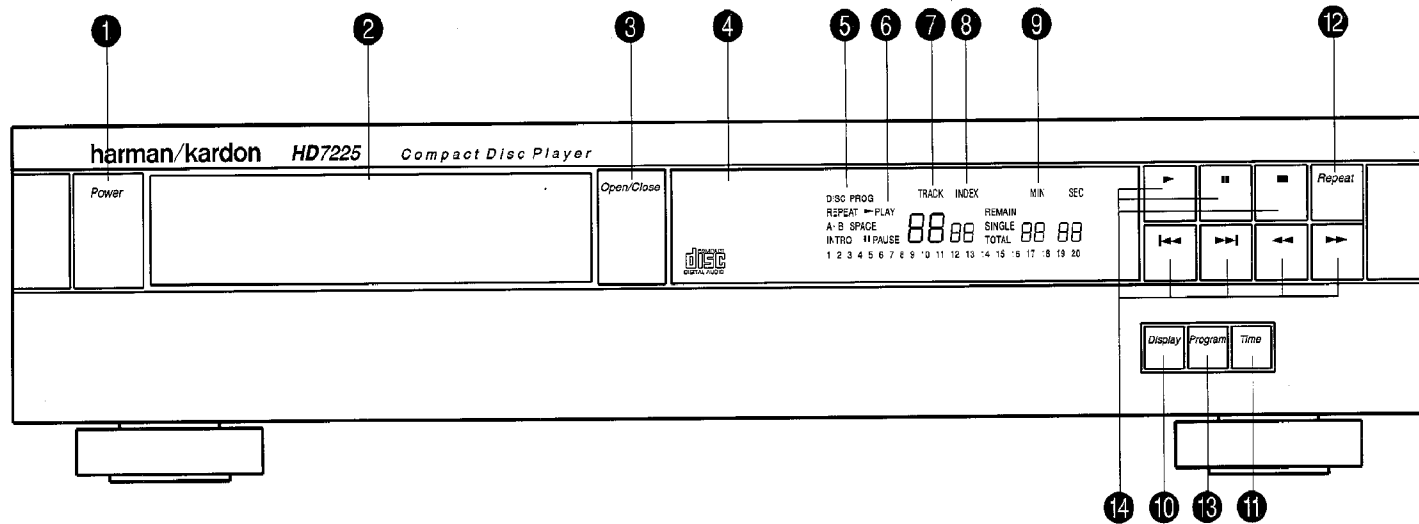

1 POWER switch

The power switch turns the unit on and off.

2 Compact disc drawer

Load a disc (full-size or 3-inch/8-cm) into your compact disc player by placing it in this drawer with the label side up. Open and close the drawer using the OPEN/CLOSE button.

3 OPEN/CLOSE button

Press this button to open or close the compact disc drawer. The drawer will also close if you press the play button or push the drawer gently toward the chassis of the player; however, we recommend that you do not push the drawer.

4 REMOTE SENSOR (HD7225 ONLY)

This area receives the signal from the remote control unit. Make sure this area of the front panel is kept free from dirt or other obstructions that might prevent proper reception of the infrared signal from the remote control.

5 FUNCTION indicator

DISC - This indicator lights when the disc drawer is open, and when a disc is loaded. It does not light when there is no disc.

REPEAT - When this indicator is lit, the unit is in REPEAT mode and will continuously repeat either the entire disc or the programmed sequence.

A-B (HD7225 only)- When this indicator is lit steadily, the unit is set to repeat a specified section of the disc (from A to B). When REPEAT indicator is lit, you have already programmed the starting point (point A) of a section, and the unit is waiting for you to program the ending point of the section (point B).

INTRO (HD7225 only)- When this indicator is lit, the unit is in INTRO SCAN mode and will play only the first 15 seconds of each selection on the disc or in the selected program.

PROG - When this indicator is lit, the unit is in PROGRAM mode, in which you can program a sequence of tracks in the order

you'd like to hear them, then play back your programmed sequence.
SPACE (HD7225 only)- When this indicator is lit, the unit is in SPACE mode and will insert 4 seconds of space between tracks.

6 PLAYBACK mode

PLAY - This indicator is lit when the unit is playing a track.

PAUSE - This indicator is lit when the unit is in PAUSE mode (i.e., you have pressed PAUSE to temporarily stop playback).

7 TRACK indicator

When a disc is loaded but not playing, the TRACK indicator displays the total number of tracks



on that disc. During playback, the indicator displays the number of the track currently being played. During programming, it displays the number of the track most recently selected.

8 INDEX indicator

Some discs that contain very long tracks may have those tracks subdivided into shorter sections. For example, a long classical piece may be divided into movements, each of which may have an index number. The INDEX indicator displays the number of the subdivision of a track currently being played. If the track has no subdivisions, the INDEX indicator will display a 1 during playback. During programming, the INDEX light goes out and the indicator displays the total number of tracks selected in the programmed sequence.

9 TIME indicator

When a disc is loaded but not playing, the TIME indicator displays the total amount of playback time on that disc. During playback, depending on the state of the TIME button (11), the indicator displays one of the following

- The time that has elapsed since the beginning of the current track.

- The time that remains on the currently selected track. The words REMAIN SINGLE will be displayed if the indicator is in this mode.
- The time that remains on either the entire disc or on the programmed selections. The words REMAIN TOTAL will be displayed if the indicator is in this mode. Note that if you have programmed more than 99 minutes in your selection, only dashes will appear in this mode.

10 DISPLAY button

This button turns the display on and off. When you turn the display off in PLAY MODE, the entire display goes off. In PAUSE mode, most of the display goes off, but the track number is still displayed. In STOP mode, most of the display goes off, but the total number of tracks on the disc is still displayed. In some systems, turning the fluorescent display off may provide the purest possible sound quality during playback.

11 TIME button

During playback or programming, the button cycles through the three TIME display modes

- The time that has elapsed since the beginning of the current track.
- The time that remains on the currently selected track.
- The time that remains on either the entire disc or the programmed sequence.

12 REPEAT button

This button puts your compact disc player in and out of REPEAT mode. In REPEAT mode, the unit will continually play back either the entire disc or the programmed sequence of tracks. Press the button once to turn on REPEAT mode; press again to turn off REPEAT mode. When the unit is in REPEAT mode, the FUNCTION indicator (5) will display the word REPEAT.

13 PROGRAM button

This button puts your compact disc player in and out of PROGRAM mode. Press the button once to turn on PROGRAM mode; press again to turn it off. In PROGRAM mode, you can program a set of tracks to play in any sequence. (For instructions on programming a sequence of tracks, see the Operations section of

this manual.) When the unit is in PROGRAM mode, the FUNCTION indicator (5) will display the word PROG in red.

14 Playback controls

PLAY - ► The PLAY button starts playback of a track.

PAUSE - ■■ Pressing the PAUSE button temporarily stops playback. Pressing the PAUSE button again, or pressing PLAY, resumes playback at the precise point where playback left off.

STOP - ■ The STOP button stops playback. When you press PLAY, playback will start either at the beginning of the disc or programmed sequence, or at any track you select.

SKIP BACK - ◀ Pressing this button once skips back to the beginning of the present track. If you are in PLAY mode, playback will resume. Holding the button down skips backward to the beginning of each preceding track until the first track is reached.

SKIP FORWARD - ▶▶ Pressing this button once skips forward to the beginning of the next track. If you are in PLAY mode, playback will resume. Holding the button down skips forward to the beginning of



HD7225 REMOTE CONTROL

each subsequent track until the last track on the disc is reached.

SEARCH BACK - ◀ Holding down this button during playback reverses rapidly through the disc. This function is similar to the "Rewind" function on a tape deck.

SEARCH FORWARD - ▶ Holding down this button during playback speeds rapidly forward through the disc. This function is similar to the "Fast forward" function on a tape deck.

HD7225 REMOTE CONTROL

The remote control for the HD7225 provides the same functions found on the front panel of the compact disc player itself. In addition, the remote control provides some functions that are not found on the front panel. The functions found on the remote control that are not found on the front panel are CHECK, CLEAR, A-B, INTRO, INDEX, SPACE, and the 1-10 and +10 keys. These five functions are described below (for other functions, see the descriptions above).

15 CLEAR button

The CLEAR button removes tracks from your programmed sequence one by one starting with the first track entered. Each time you clear a track from the programmed sequence, that track's time is deleted from the total time displayed. This button is used only in PROGRAM mode.

16 CHECK button

When a disc is loaded but not playing (STOP mode), you can press the CHECK button to see the playback time of each track on the disc. Each time you press the CHECK button, the next track is displayed along with its playback time. When you have stepped sequentially through all the tracks on the disc, another press of the CHECK button displays the total playback time of the entire disc. In PROGRAM mode, the CHECK button displays the cumulative time of the tracks in the programmed sequence. That is, the first press displays the time of the first programmed track, the second press displays the cumulative playback time of the first and second tracks, and so on.

17 A-B button

This button puts our compact disc player in and out of A-B mode. In A-B mode, the unit will continually play back a "phrase" or section of your disc beginning at point A and ending at point B. (For instructions on repeating a section of a disc, see the Operations section of this manual.) When the unit is in A-B mode, the FUNCTION indicator (5) will display REPEAT A-B.

18 INTRO button

This button puts your compact disc player in and out of INTRO SCAN mode. When INTRO SCAN is on and you press PLAY, the unit plays only the first 15 seconds of each track before moving on to the next. Press the button once to turn on INTRO SCAN mode; press again to turn it off and stop the scanning. When the unit is in INTRO SCAN mode, the FUNCTION indicator (5) will display the word INTRO.

19 SPACE button

This button puts your compact disc player in and out of SPACE mode. Press the button once to turn on SPACE MODE; press again to turn it off. In SPACE mode, the unit inserts 4 seconds of blank space between tracks. This is particularly useful if

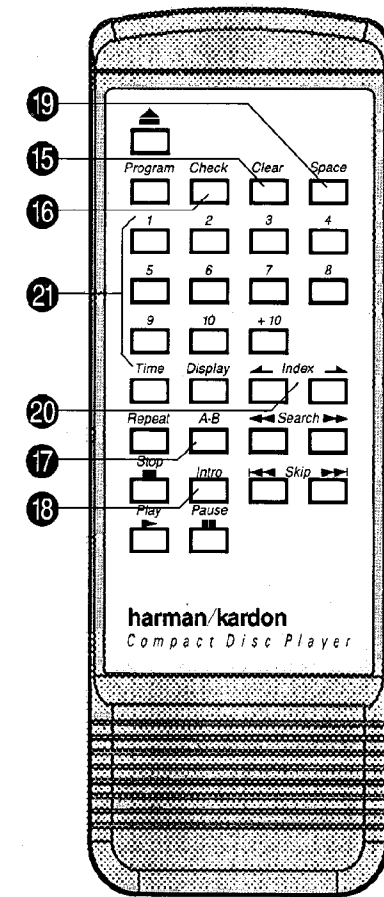

you are recording music from a compact disc onto a tape. Tape decks with a Music Search feature will be able to use the 4 seconds of space to correctly identify the beginning of each selection on the tape. When the unit is in SPACE mode, the FUNCTION indicator (5) will display the word SPACE.

CONNECTIONS

20 INDEX button

Some discs contain long selections that may be subdivided into shorter sections (for example, operas). Just as the tracks are marked by the track number, these shorter sections may be marked by index numbers. When you have started playback of the desired track, you can use the INDEX UP and INDEX DOWN buttons to jump to a desired index selection. Each time you press and INDEX button, the INDEX indicator displays the next higher or lower index number. If you continue pressing the button until the indicated index number is higher than the actual number of index selections on the disc, playback will start from the nearest index selection.

21 Track selection buttons

This set of buttons (numbered 1 through 10 and +10) enables you to directly select the track you want to play. To select a track with a number higher than 10, press the +10 button, then press the button that will add up to the number of the track you want. For example, to select track 14, press +10, then press 4. If you select a track number that does not exist on your disc, the TRACK indicator will

continue to display the number of the last track on the disc. When PROGRAM mode is off, pressing a track button plays the track you select. When PROGRAM mode is on, pressing a track button programs that track into your sequence.

Standard Connections

Before you begin to connect this unit to your system, be sure that all components are turned off and unplugged from the electrical outlet. On the back of your HD7125/HD7225 are output jacks that connect your CD player to your receiver, integrated amplifier, or preamplifier. Using the supplied shielded cords, connect the left and

right output jacks on the back of the CD player to the left and right input jacks marked CD or AUX on the back of your receiver/preamplifier/integrated amplifier. Alternatively, you can also use the TAPE INPUT or TAPE PLAY jacks on your receiver/preamplifier/integrated amplifier.

Note: NEVER connect your CD player to the PHONO inputs.

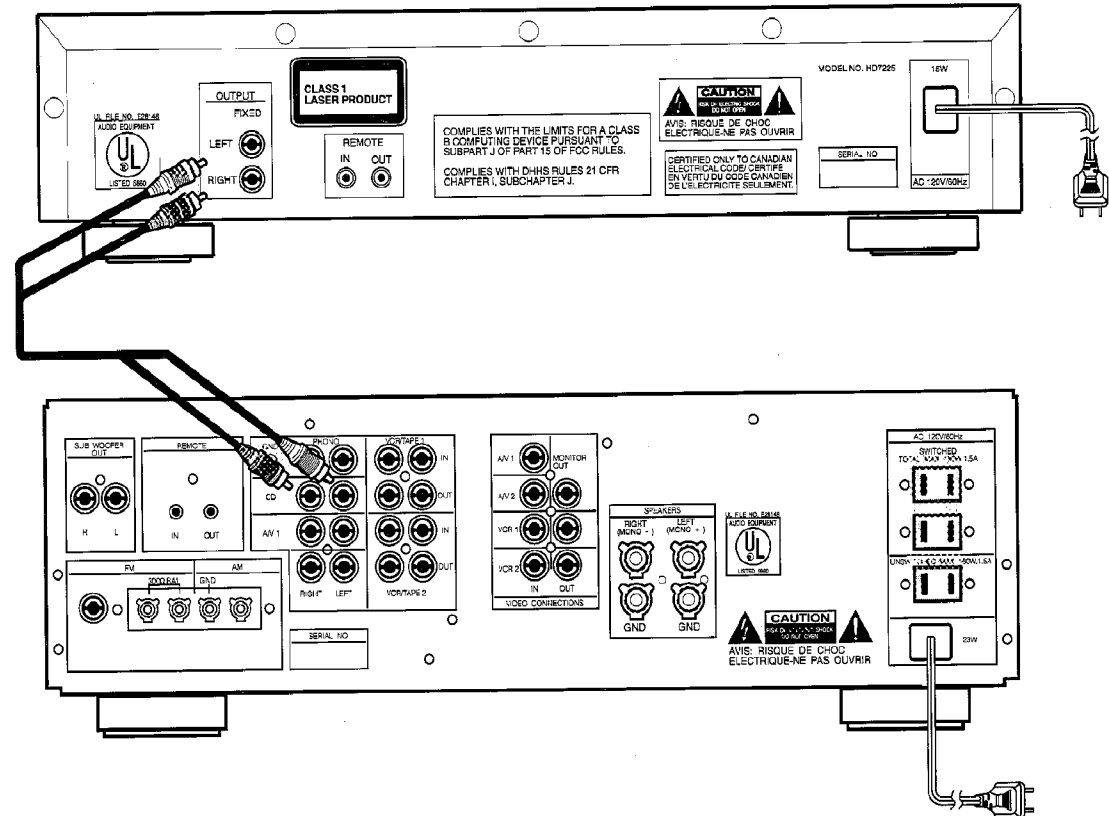

General Connection Hints

As you connect your compact disc player, carefully connect the plugs to the output jacks, being sure to push the plugs in all the way. Loose connection of a plug can cause hum or other intermittent noise. Take care to match the left and right plugs on the CD player with the left and right input jacks on the back of the receiver/preamplifier/integrated amplifier. Common practice is to use the red plug as right, and the white, gray, or black plug as left.

Do not wind the cables with the power cord; doing so may degrade the sound quality.

When you have finished connecting your HD7125/HD7225 to your receiver/preamplifier/integrated amplifier, plug the power cord of the CD player either into a power outlet on the back of another component, or into the power outlet in the wall.

HD7225 Remote Control Operation

Two batteries are provided with your remote control. To load batteries

1. Locate the cover over the battery compartment on the back of the remote control. Remove the cover by sliding it in the direction of the embossed arrow.
2. Insert the two AA (1.5V/R6/UM3) batteries. Make sure you insert the batteries according to the + and - polarity symbols at the bottom of the battery compartment.
3. Replace the cover of the battery compartment.

When you replace weak batteries, replace both at the same time.

The remote control operates within a 30° angle of the remote sensor on the front panel of the unit. Make sure that the remote's front projection "lens" as well as the REMOTE SENSOR area on the front panel of the unit are kept free from dirt to ensure proper transmission and reception of the infrared beam. Also make sure that no objects (e.g., stereo cabinet doors, end tables) block the path from the remote control to the REMOTE SENSOR area.

Avoid using the remote control near fluorescent lamps, as they may shorten its operating range.

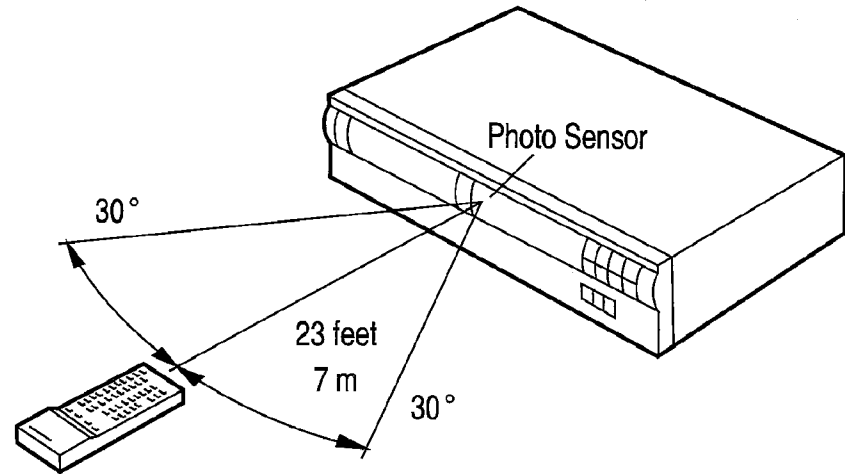

Remote Control Unit

If your remote control will sit unused for a long period of time, remove the batteries to prevent damage from corrosion.

HD7125/HD7225 Rear Panel Remote Jacks

The remote control input jack allows remote control of this unit via a cable. This cable can be connected to the remote control output jack of another Harman Kardon product. Alternatively, it can be connected to

an accessory device that converts infrared remote control signals into detected pulses. The system controllers included with all Harman Kardon remote-controlled receivers provide the basic CD player features such as play, stop, and skip. While all Harman Kardon products with remote control jacks are compatible with one another, not all accessory devices are other manufacturer's products are. However, it is safe to experiment.

PLAYER OPERATION

Care and handling of compact discs

With care, a CD will last forever. However, dust scratches, or warps can lead to noise or playback problems.

Hold the compact disc only by the outer edge, supporting it at the center hole with your index finger if necessary. Be careful not to touch the unprinted side of the disc - this is the side the laser reads. Never glue any labels or stickers to either side of the disc.

If a CD does become dirty, clean it with a commercially available compact disc cleaning kit or with a silicone cloth such as those used for cleaning camera lenses. Never use chemical substances such as

alcohol, record cleaners intended for analog phonograph records, or anti-static fluids.

After you play a compact disc, return it to its plastic case. Avoid storing the disc in a location that is subject to direct sunlight, high humidity, or high temperatures.

Playing a compact disc

Because of the extremely wide dynamic range made possible by digital recording, a sudden high volume may result if you attempt to adjust your volume control by "background noise level" the way you might with records or cassette tapes. To avoid damage to speakers or headphones, keep the volume moderate until you are

familiar with the sonic performance of compact discs.

1. Press the POWER button to turn on your compact disc player.
2. Press the OPEN/CLOSE button and place the compact disc into the drawer with the label facing up.
3. Press the OPEN/CLOSE button to close the drawer. The number of tracks on the disc and the total playing time will be displayed. The small numbers along the bottom of the display indicate how many tracks there are on the disc. The small number for the track will go out as each track finishes playing.
4. Press the PLAY button either on the front panel or on the remote control.

To stop playback, press the STOP button.

To pause during playback, press the PAUSE button. The PAUSE light in the display will light up. To resume playback, press either the PAUSE or PLAY button.

Note: When you load a disc, the HD7125/HD7225 reads the disc and stores information on up to 20 tracks in its internal memory. It uses this information for calculating total and remaining playback time. If the disk you load has more than 20 tracks on it, the unit will store information about only the first 20 tracks. If you attempt to use the CHECK button to see the total playback time, for example, the indicator will display only dashes, since it does not have information about all the tracks on the disc.

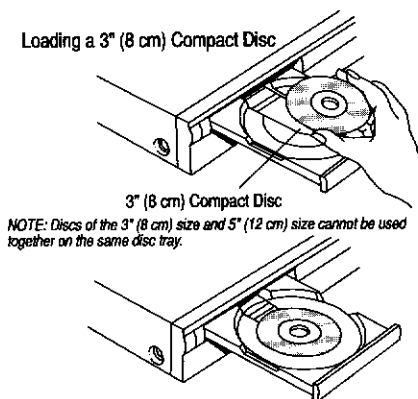
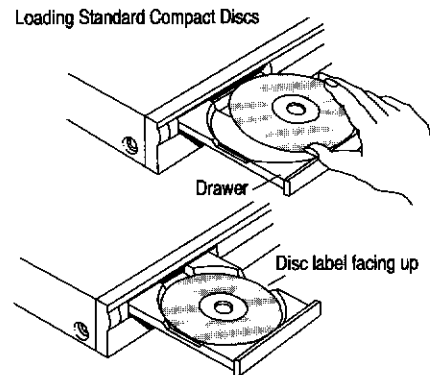
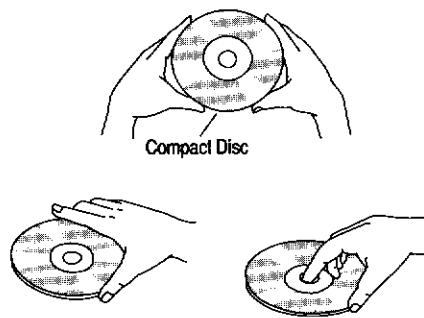

Playing a particular track

Tracks can be selected directly via the 1-10 and +10 keys on the HD7225 remote control (see page 7). Tracks can also be selected by using the front panel SKIP BACK and SKIP FORWARD buttons. After loading a disc, press the SKIP buttons repeatedly until the desired track number is shown in the display. Then press PLAY.

Particular tracks can also be selected in the same way while a disc is playing. However, in this case, the selected track will automatically begin playing.

Skipping quickly to the beginning of other tracks

While a CD is playing, press one of the SKIP buttons (either SKIP BACK or SKIP FORWARD) until the number of the track you want to play is displayed.

The unit skips to the beginning of the displayed track and begins playing. If you press the SKIP BACKWARD button only once during playback, the unit skips back to the beginning of the same track and begins playing.

Manually searching

While a CD is playing, press one of the SEARCH buttons (either SEARCH BACK or SEARCH FORWARD) until you locate the part of the disc you want to hear. If you SEARCH BACK all the way to the beginning of track 1, playback will automatically begin there, even if you continue to hold down the SEARCH BACK button. If you SEARCH FORWARD all the way to the end of the disc, searching will stop there. Searching during PROGRAM or REPEAT mode, the unit will scan rapidly wither to the end or the beginning of the current track, then playback at normal speed will begin. The HD7125/HD7225 automatically lowers the volume during a search, although you can still hear the speeded-up sound. To switch to rapid but inaudible search, press the PAUSE button before using the search button. Then to resume playback, press either PAUSE or PLAY.

Programming a sequence of tracks

The HD7125/HD7225 will memorize a sequence of up to 20 tracks and then play them back in the order they were programming. Your programmed sequenced can be 20 different songs or a combination with individual songs repeated several times as part of the sequence.

1. Load a disc into your CD player.
2. Press the PROGRAM button either on the front panel or on the remote control. The red PROG indicator in the display lights up and the INDEX light goes out.
3. Select the first track by either pressing its number on the remote control keypad or using the front panel or remote control SKIP buttons. If you select the track using the skip buttons, you must then press the PROGRAM button on the front panel or on the remote control to enter the number of the selected track. The number of that track appears in the display along with its time. The small number of the track at the bottom of the display also lights up to indicate that you have chosen that track as part of your programmed sequence. This row of small numbers is called the music calendar. The indicator to the right of the TRACK indicator (where the

INDEX number is displayed in non-PROGRAM mode) displays the total number of selections that you have programmed.

4. Select the next track of your desired sequence in the same way as described in Step 3. The display indicates the track number as well as the cumulative playback time in your sequence (the time of this track added to the time of the previous track).
5. Continue until up to 20 tracks have been programmed. To repeat a track, simply enter its number again to add it to the selection. If you want to delete the last track selected, press the CLEAR button. The track will be deleted and its time will be subtracted from the total playback time display. Each time you press CLEAR, the most recently programmed track will be deleted. To clear an entire programmed selection, press the STOP button twice. Then start over from step 2, above. To check the time of the tracks in the programmed sequence, press the CHECK button. Each time you press the CHECK button, the next higher track in the sequence will be displayed along with the cumulative playing time of all tracks checked to that point. After all tracks have been checked, a final press of

the button will display the total playback time of the programmed sequence.

6. When you are finished programming, press the PLAY button. The HD7125/HD7225 will begin playing on the first track you programmed and continue playing tracks in the order programmed. The small track numbers at the bottom of the display (the music calendar) indicate which tracks in the programmed sequence still remain to be played.

■ During playback of a programmed sequence, you can use the SKIP and SEARCH functions without canceling the program. SKIP will jump to the beginning of each track in the programmed sequence, and SEARCH will scan quickly through each track in the programmed sequence.

■ To stop playback of a programmed sequence, press STOP once. The sequence remains programmed, and you can add more tracks to the program at this point. Press PLAY to start playback again.

■ To stop playback of a programmed sequence and cancel the program, press STOP twice. The PROG light in the display goes out.

Repeating the entire CD or programmed sequence

1. Press the REPEAT button either on the front panel or on the remote control. The REPEAT indicator in the display lights up.

■ You can press REPEAT at any time either before or during playback. When the unit is in REPEAT mode, it will continuously play the entire CD or the programmed sequence.

■ To turn off REPEAT mode, press the REPEAT button again. If you turn off REPEAT during playback, the unit will continue to play until the end of the disc or the programmed sequence.

■ You can use both SKIP and SEARCH functions as usual when in REPEAT mode.

Repeating a single track

1. Press PROGRAM.

2. Select the desired track by either pressing its number on the remote control keypad or using the front panel skip buttons.

3. Press REPEAT.

4. Press PLAY. The track will be repeated continuously until you turn off REPEAT.

Repeating a "phrase" or section of the disc

The HD7225 allows you to repeat any continuous section of the disc from a specified starting point (A) to a specified ending point (B).

1. Press PLAY.

2. When you hear the point where you want to begin your "phrase", press the A-B button on the remote control. Pressing this button marks point A (the starting point of the phrase). The REPEAT indicator in the display will light and the disc continues to play.

3. When you hear the point where you want your phrase to the end, press the A-B button again. The A-B indicator in the display will light. The unit is now in A-B mode and will continue to repeat the section that you chose until you either press STOP or press the A-B button again.

Note: A-B repeat works only during normal playback mode, not in PROGRAM mode.

Timer playback

When the power is turned on to the unit, it will begin playing automatically if it has a disc in it. If you plug the compact disc player into an ordinary timer, you can have it begin playback at a preset time.



TROUBLESHOOTING

If your HD7125/HD7225 does not operate as expected, first check the items in the following list. If you cannot determine the source of the problem, contact your dealer or authorized Harman Kardon service representative.

SYMPTOM	PROBABLE CAUSE/SOLUTION
No lights on the front panel	<ul style="list-style-type: none">■ Power cord is not plugged into power outlet.■ Wall outlet or extension cord is faulty. Check for poor connections.■ Breaker on plug strip has tripped. Reset breaker.
Front panel lights are on, but the CD does not play	<ul style="list-style-type: none">■ The disk may have been inserted upside down. Make sure that the label side is facing up.■ Moisture may have formed on the laser/receptor inside the unit. This sometimes occurs in damp climates or when the unit is moved from a cold to a warm area. Leave the unit turned on at room temperature for 30 minutes to allow the moisture to evaporate, then play your disc.
The PLAY indicator lights, but no sound is heard	<ul style="list-style-type: none">■ The wrong SOURCE has been selected on your integrated amplifier/receiver/preamplifier. Make sure you have selected the SOURCE where your CD player is connected.■ You have connected the unit to your receiver/preamplifier/integrated amplifier using the VARIABLE output jacks, and the OUTPUT LEVEL control on the front panel is turned down all the way. Turn the OUTPUT LEVEL control up to the desired volume.
The sound skips or stutters during playback	<ul style="list-style-type: none">■ The disc may be dirty or damaged.■ The unit may have been placed on an unstable surface. Isolate the unit from excessive vibration by placing it on a firmer surface or farther away from your speakers.
The sound is continuously distorted	<ul style="list-style-type: none">■ The cables from the HD7125/HD7225 have been plugged into the wrong input jacks on your integrated amplifier/receiver/preamplifier. Make sure you have not plugged the unit into the PHONO jacks.
Nothing happens when function keys are pressed	<ul style="list-style-type: none">■ Turn the power to the unit off, then back on again.■ The display shows broken characters. Turn the power to the unit off, then back on again.
The remote control does not function correctly	<ul style="list-style-type: none">■ Make sure you are using the remote control within the 30 degree angle described in this manual.■ Make sure the remote transmitter lens and the front panel window are clean and that no objects are blocking the path from the remote control to the REMOTE SENSOR area on the front panel.■ Make sure that no strong fluorescent lights are being used in the listening room.■ Check that the batteries inside the remote control are fresh.





SPECIFICATIONS

System:	Compact Disc Digital Audio
D/A Converter:	3D Bit Stream MASH/PWM, 18 bit/4X digital filter
Signal Detection:	3-Beam Semiconductor; Optical Laser Pickup
Error Correction:	CIRC System
Low Level Linearity:	+/-1.0dB @-90dB
Frequency Response:	4Hz to 20kHz +0dB/-1.5dB
Total Harmonic Distortion(THD):	0.008%
Dynamic Range:	96dB
Signal to Noise Ratio:	103dB
Channel Separation:	89dB
Line Output Level/Impedance:	1.8V @ 10 Ω
Power Consumption:	15 Watts
Dimensions:	17.4" x 3.6" x 13" (443mm x 92mm x 326mm).
Weight:	11.5 lbs (5.2kgs)



WARRANTY INFORMATION (USA ONLY)

SERVICE

Any necessary repairs or adjustments must be performed at the factory or by an authorized service center. In the event that service is required, call 1.800.645.7484 for assistance.

WARRANTY

This limited warranty protects the original owner of a Harman Kardon HD7125 and HD7225 for a period of two years from date of purchase. The original, dated bill of sale or an on-file registered warranty is required to obtain service.

LIMITATION ON IMPLIED WARRANTIES

Implied warranties of merchantability and fitness for a particular purpose are limited in duration to a period of one year from the date of purchase. Some states do not allow limitations on how long an implied warranty lasts, so the above limitation may not apply to you.

EXCLUSIONS OF CERTAIN DAMAGES

Harman Kardon shall not be liable or in any way responsible for any incidental or consequential damages of any kind. Some states do not allow limitation on how long an implied warranty lasts and/or do not allow the exclusion of incidental or consequential damages, so the

above limitations and exclusions may not apply to you. This warranty gives you specific legal rights, and you may also have other rights which vary from state to state.

WHAT IS COVERED BY THE WARRANTY

Your warranty covers all defects in material and workmanship when shipped in its original container, with the following specific exceptions. These are:

(1) damage to or deterioration of any accessory or decorative surface; (2) damage caused by improper installation or adjustment; (3) damage caused by accident, unreasonable use or neglect; (4) damage from failure to follow instructions contained in this manual; (5) damage from the performance of unauthorized repairs or modifications; (6) any unit on which the serial number has been effaced, modified, or removed; (7) damage occurring during shipment; and (8) units which have been altered or modified in design, appearance or construction. This warranty covers only the actual defects within the product itself, and does not cover the costs of installation or removal from a fixed installation, normal set-up or adjustments, claims based on any

misrepresentation by the seller, or performance variations resulting from installation related circumstances such as program source quality or AC power.

WHAT IS THE PERIOD OF COVERAGE

This warranty protects the original owner of a Harman Kardon HD7125 or HD7225 purchased and used for a non-commercial, residential use for a period of two years (parts and labor) from the original date of purchase.

WHO IS COVERED BY THE WARRANTY

Your warranty protects the original owner, so long as the original bill of sale is presented when the warranty service is required. This warranty protects only the original owner, and is invalid as to all subsequent owners of the product.

WHAT WE WILL DO TO CORRECT PROBLEMS

Harman Kardon will, at its option, either repair or replace the defect, or replace the defective product or part thereof at no charge to the owner for parts and labor covered by this warranty. If necessary repairs are not covered by this warranty or if a unit is examined which is not in need of repair, you will be charged for the repairs or the examination.

You must pay any shipping charges incurred in returning your product to Harman Kardon. We will pay the return surface UPS shipping charges if the repairs are covered by the warranty. Please save the original shipping carton and internal packaging. A charge will be made for replacement shipping materials.

HOW TO OBTAIN WARRANTY

If your product needs service, you must notify your authorized dealer or call us at:
HARMAN KARDON
1.800.645.7484

Our postal mailing address for correspondence is:
240 Crossways Park West
Woodbury, NY 11797

